

ARMY TM 11-5865-202-20P
NAVY NAVAIR 16-35ALQ136-4.1

TECHNICAL MANUAL

**AVIATION UNIT MAINTENANCE REPAIR PARTS
AND SPECIAL TOOLS LIST**

FOR

COUNTERMEASURES SET

AN/ALQ-136(V)1

(NSN 5865-01-127-6880]

<p>This publication has been printed by the UNITED STATES ARMY PUBLICATIONS DISTRIBUTION CENTER, ST. LOUIS, MISSOURI, to meet your needs on a timely basis.</p>

DEPARTMENTS OF THE ARMY AND THE NAVY

30 MARCH 1984

TECHNICAL MANUAL
No. 11-5865-202-20P
TECHNICAL MANUAL
NAVAIR 16-35ALQ136-4.1



DEPARTMENT OF THE ARMY
AND THE NAVY

WASHINGTON, DC, 30 March 1984

**AVIATION UNIT MAINTENANCE
REPAIR PARTS AND SPECIAL TOOLS LIST
FOR
COUNTERMEASURES SET AN/ALQ-136(V)1
(NSN 5865-01-127-6880)**

Current as of 1 February 1984

REPORTING ERRORS AND RECOMMENDING IMPROVEMENTS

You can help improve this manual. If you find any mistakes or if you know of a way to improve the procedures, please let us know. Mail your letter, DA Form 2028 (Recommended Changes to Publications and Blank Forms), or DA Form 2028-2 located in back-of this manual direct to: Commander, US Army Communications - Electronics Command and Fort Monmouth, ATTN: DRSEL-ME-MP, Fort Monmouth, NJ 07703.

For Navy, mail comments to the Commander, Naval Electronic Systems Command, ATTN: ELEX 8122, Washington, DC 20360.

In either case, a reply will be furnished direct to you.

Table of Contents

	Page	Illus Figure
SECTION I. Introduction	1	
II. Repair Parts List	5	
GROUP 00 Countermeasures Set AN/ALQ-136(V)1	5	1
02 Antenna AS-3007/ALQ-136(V)	7	2
(13 Antenna AS-3007/ALQ-136(V) (See Group 02 for parts)		
SECTION III. Special Tools List (Not applicable)		
IV. National Stock Number and Part Number Index	8	

SECTION I INTRODUCTION

1. Scope

This manual lists spares and repair parts, special tools; special test, measurement, and diagnostic equipment (TMDE), and other special support equipment required for performance of aviation unit maintenance (AVUM), of the AN/ALO-136(V)1. It authorizes the requisitioning and issue of spares and repair parts as indicated by the source and maintenance codes.

2. General

This Repair Parts and Special Tools List is divided into the following sections:

a. Section II. Repair Parts List. A list of spares and repair parts authorized for use in the performance of maintenance. The list also includes parts which must be removed for replacement of the authorized parts. Parts lists are composed of functional groups in numeric sequence, with the parts in each group listed in figure and item number sequence.

b. Section III. Special Tools List. Not applicable.

c. Section IV National Stock Number and Part Number Index. A list, in National item identification number (NIIN) sequence, of all National stock numbers (NSN) appearing in the listings, followed by a list, in alphameric sequence, of all part numbers appearing in the listings. National stock numbers and part numbers are cross-referenced to each illustration figure and item number appearance.

3. Explanation of Columns

a. Illustration. This column is divided as follows:

(1) *Figure number.* Indicates the figure number of the illustration on which the item is shown.

(2) *Item number.* The number used to identify item called out in the illustration.

b. Source, Maintenance, and Recoverability (SMR) Codes.

(1) *Source code.* Source codes indicate the manner of acquiring support items for maintenance, repair, or overhaul of end items. Source codes are entered in the first and second positions of the Uniform SMR Code format as follows:

<i>Code</i>	<i>Definition</i>
PA	Item procured and stocked for anticipated or known usage.

NOTE

Cannibalization or salvage may be used as a source of supply for any items source coded above except those coded XA and aircraft support items as restricted by AR 750-1.

(2) *Maintenance code.* Maintenance codes are assigned to indicate the levels of maintenance authorized to USE and REPAIR support items. The maintenance codes are entered in the third and fourth positions of the Uniform SMR Code format as follows:

(a) The maintenance code entered in the third position will indicate the lowest maintenance level authorized to remove, replace, and use the support item. The maintenance code entered in the third position will indicate one of the following levels of maintenance:

<i>code</i>	<i>Application/Explanation</i>
O	Support item is removed, replaced, used at the aviation unit maintenance level.

(b) The maintenance code entered in the fourth position indicates whether the item is to be repaired and identifies the lowest maintenance level with the capability to perform complete repair (i.e., all authorized maintenance functions). This position will contain one of the following maintenance codes:

<i>Code</i>	<i>Application/Explanation</i>
D	The lowest maintenance level capable of complete repair of the support item is the depot level.

Z – Nonreparable. No repair is authorized.

(3) *Recoverability code.* Recoverability codes are assigned to support items to indicate the disposition action on unserviceable items. The recoverability code is entered in the fifth position of the Uniform SMR Code format as follows:

<i>Recoverability codes</i>	<i>Definition</i>
Z	Nonreparable item. When unserviceable, condemn and dispose at the level indicated in position 3.
D	Reparable item. When beyond lower level repair capability, return to depot. Condemnation and disposal not authorized below depot level.

c. National Stock Number. Indicates the National stock number assigned to the item and will be used for requisitioning purposes.

d. Part Number. Indicates the primary number used by the manufacturer (individual, company, firm, corporation, or Government activity), which controls the design and characteristics of the item by means of its engineering drawings, specifications, standards, and inspection requirements to identify an item or range of items

NOTE

When a stock numbered item is requisition the repair part received may have a different part number than the part being replaced

e. Federal Supply Code for Manufacturer (FSCM). The FSCM is a 5-digit numeric code listed in SB 708-41/42 which is used to identify the manufacturer, distributor, or Government agency, etc.

f. Description. Indicates the Federal item name and, if required, a minimum description to identify the item.

g. Unit of Measure (U/M). Indicates the standard of the basic quantity of the listed item as used in performing the actual maintenance function. This measure is expressed by a two-character alphabetical abbreviation (e.g., ea, in, pr, etc). When the unit of measure differs from the unit of issue, the lowest unit of issue that will satisfy the required units of measure will be requisitioned.

h. Wantity Incorporated in Unit. Indicates the quantity of the item used in the breakout shown on the illustration figure, which is prepared for a functional group, subfunctional group, or an assembly.

4. Special Information

a. The following publication pertains to the AN/ALQ-136(V)1 and its components:

TM 11-5865-202-12 Countermeasures Set AN/ALQ-136(V)1

b. The illustrations in this manual are identical to those published in TM 11-5865-202-30P. Only those parts assigned the third position SMR maintenance code "C" or "O" are listed in the tabular listing; therefore, there may be a break in the item number sequence. Only illustrations containing aviation unit authorized items appear in this manual.

c. National stock numbers (NSN'S) that are missing from P source coded items have been applied for and will be added to this TM by future change/revision when they are entered in the Army Master Data File (AMDF). Until

the NSN's are established and published, submit exception requisitions to: Commander, US Army Communications Electronics Command and Fort Monmouth, ATTN: DRSEL-MM, Fort Monmouth, NJ 07703 for the part required to support your equipment.

5. How to Locate Repair Parts

unknown.

(1) *First.* Using the table of contents, determine the functional group within which the item belongs. This is necessary since illustrations are prepared for functional groups and listings are divided into the same groups.

(2) *Second.* Find the illustration covering the functional group to which the item belongs.

(3) *Third.* Identify the item on the illustration and note the-illustration figure and item number of the item.

(4) *Fourth.* Using the Repair Parts Listing, find the figure and item number noted on the illustration.

b. When National stock number or part number is known.

(1) *First.* Using the Index of National Stock Numbers and Part Numbers, find the pertinent National stock number or part number. This index is in NIIN sequence followed by a list of part numbers in alphameric sequence, cross-referenced to the illustration figure number and item number.

(2) *Second.* After finding the figure and item number, locate the figure and item number in the repair parts list.

6. Abbreviations

Not applicable.

(next printed page is 4)

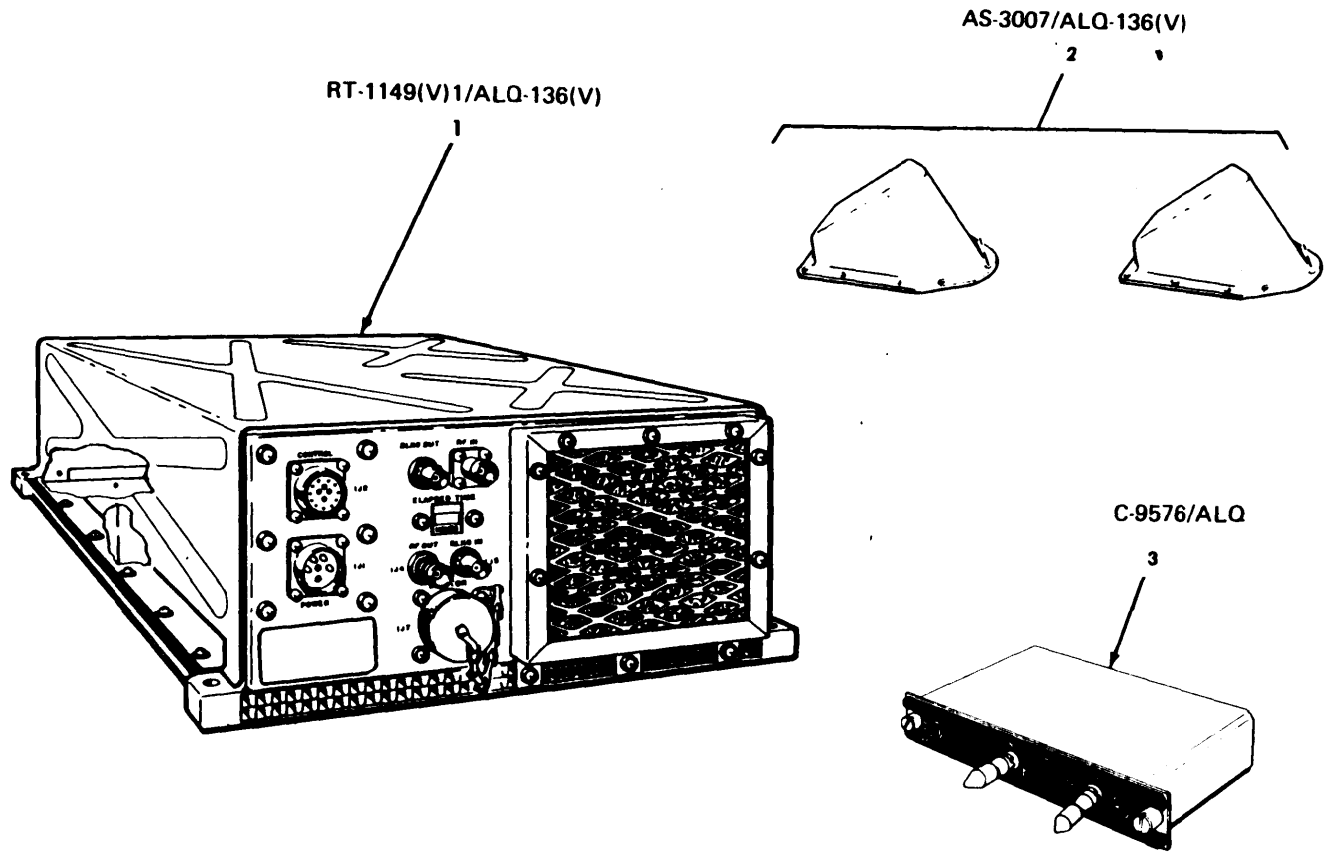

EL3WO001

Figure 1. Countermeasures Set AN/ALQ-136(V)1.

Figure 1.

SECTION II. REPAIR PARTS LIST

SECTION II		TM11-5865-202-20P/NAVAIR 16-35ALQ136-4.1					
(1)	(2)	(3)	(4)	(5)	(6)	(7)	(8)
ILLUSTRATION					DESCRIPTION		QTY
(A)	(B)	NATIONAL		PART			INC
FIG	ITEM	STOCK	FSCM	NUMBER		USABLE ON CODE	IN
NO	NO	NUMBER				U/M	UNIT
					GROUP 00 COUNTERMEASURES SET		
					AN/ALQ-136(V)1		
1	1	PAPDD		RT-1149(V)1/ALQ-136(V)	RECEIVER-TRANSMITTE	EA	1
			80058				
1	2	PAODD	5865-01-125-0297	AS-3007/ALQ-136(V)	ANTENNA	EA	2
			80058				
1	3	PAODD	5865-01-100-0380	C-9576/ALQ	CONTROL, COUNTERMEAS	EA	1
			80058				

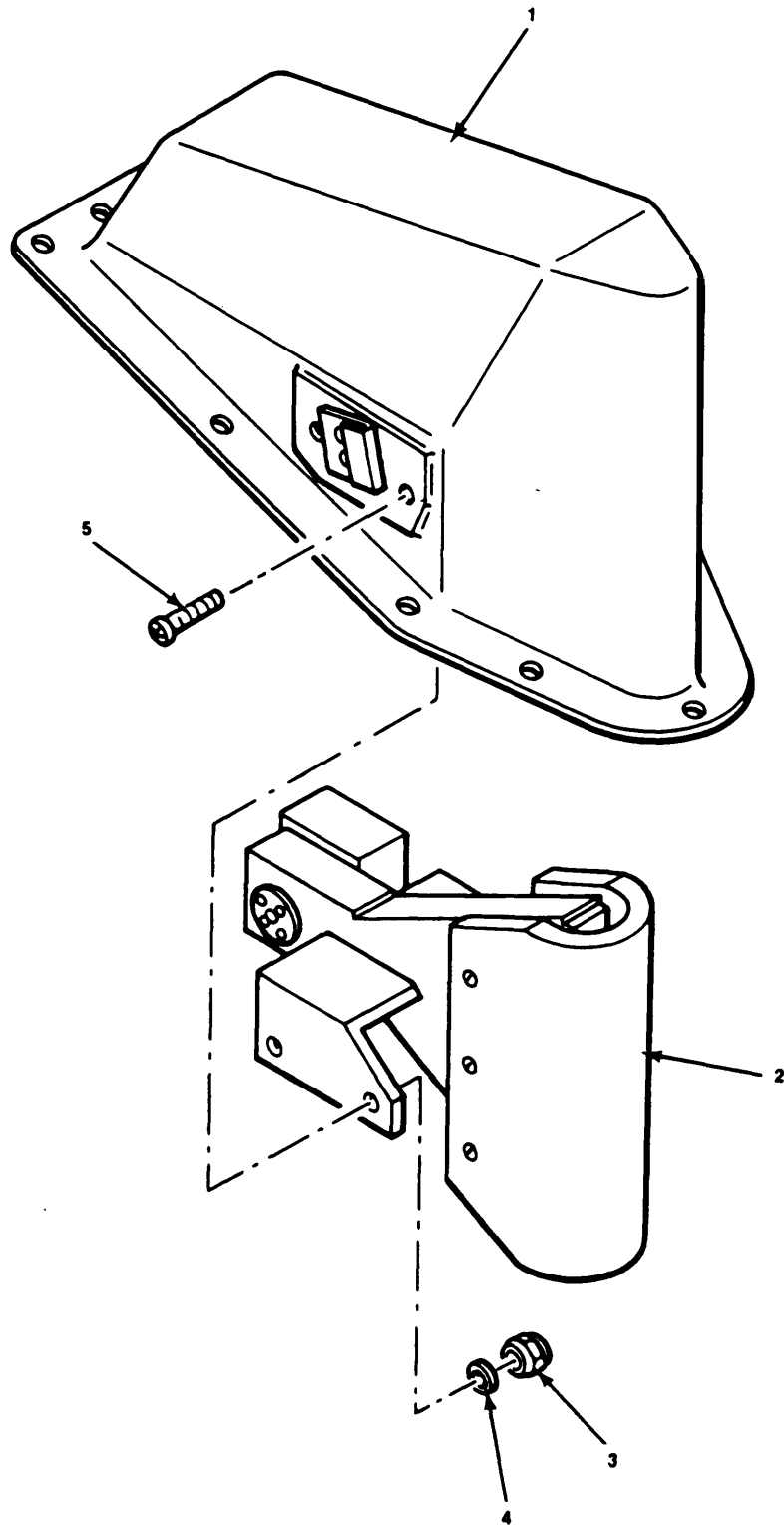

EL3W0029

Figure 2. Antenna AS-3007/ALQ-136(V).

SECTION II (1) ILLUSTRATION (A) (B) FIG ITEM NO NO		(2) SMR CODE	(3) NATIONAL STOCK NUMBER	TM11-5865-202-20P/NAVAIR 16-35ALQ136-4.1 (4) (5) FSCM PART NUMBER		(6) DESCRIPTION	(7) USABLE ON CODE U/M	(8) QTY INC IN UNIT
GROUP 02 ANTENNA AS-3007/ALQ-136(V)								
2	1	PAOZZ		80063	SM-C-991218	RADOME ASSEMBLY	EA	1
2	2	PAOZZ		80063	SM-C-991211	ANTENNA SUBASSEMBLY	EA	1
2	3	PAOZZ	5310-00-982-6814	96906	MS21044C08	NUT, SELF-LOCKING, HE	EA	4
2	4	PAOZZ	5310-00-880-5978	96906	MS15795-807	WASHER, FLAT	EA	4
2	5	PAOZZ	5305-00-891-1775	88044	AN525-832R10	SCREW, MACHINE	EA	4

SECTION IV. NATIONAL STOCK NUMBER AND PART NUMBER INDEX

SECTION IV
 NATIONAL STOCK NUMBER AND PART NUMBER INDEX

TM11-5865-202-20P/NAVAIR 16-35ALQ136-4.1

STOCK NUMBER	FIGURE NO	ITEM NO	STOCK NUMBER	FIGURE NO	ITEM NO
5310-00-880-5978	2	4	5865-01-100-0380	1	3
5305-00-891-1775	2	5	5865-01-125-0297	1	2
5310-00-982-6814	2	3			

FSCM	PART NUMBER	FIGURE NO	ITEM NO	FSCM	PART NUMBER	FIGURE NO	ITEM NO
88044	AN525-832R10	2	5	96906	MS21044C08	2	3
80058	AS-3007/ALQ-136(V)	1	2	80058	RT-1149(V)1/ALQ-136(V)	1	1
80058	C-9576/ALQ	1	3	80063	SM-C-991211	2	2
96906	MS15795-807	2	4	80063	SM-C-991218	2	1

By Order of the Secretaries of the Army and the Navy:

Official

JOHN A. WICKHAM JR.
General, United States Army
Chief of Staff

ROBERT M. JOYCE
Major General, United States Army
The Adjutant General

G.B. SCHICK, JR.
Rear Admiral, United States Navy
Commander, Naval Electronics
Systems Command

Distribution:

To be distributed in accordance with special list.

RECOMMENDED CHANGES TO EQUIPMENT TECHNICAL PUBLICATIONS



THEN...JOT DOWN THE
DOPE ABOUT IT ON THIS FORM.
CAREFULLY TEAR IT OUT, FOLD IT
AND DROP IT IN THE MAIL.

SOMETHING WRONG WITH PUBLICATION

FROM: (PRINT YOUR UNIT'S COMPLETE ADDRESS)

DATE SENT

PUBLICATION NUMBER

PUBLICATION DATE

PUBLICATION TITLE

BE EXACT PIN-POINT WHERE IT IS

PAGE
NO.

PARA-
GRAPH

FIGURE
NO.

TABLE
NO.

IN THIS SPACE, TELL WHAT IS WRONG
AND WHAT SHOULD BE DONE ABOUT IT.

TEAR ALONG PERFORATED LINE

PRINTED NAME, GRADE OR TITLE AND TELEPHONE NUMBER

SIGN HERE

The Metric System and Equivalents

Linear Measure

1 centimeter = 10 millimeters = .39 inch
 1 decimeter = 10 centimeters = 3.94 inches
 1 meter = 10 decimeters = 39.37 inches
 1 dekameter = 10 meters = 32.8 feet
 1 hectometer = 10 dekameters = 328.08 feet
 1 kilometer = 10 hectometers = 3,280.8 feet

Weights

1 centigram = 10 milligrams = .15 grain
 1 decigram = 10 centigrams = 1.54 grains
 1 gram = 10 decigrams = .035 ounce
 1 dekagram = 10 grams = .35 ounce
 1 hectogram = 10 dekagrams = 3.52 ounces
 1 kilogram = 10 hectograms = 2.2 pounds
 1 quintal = 100 kilograms = 220.46 pounds
 1 metric ton = 10 quintals = 1.1 short tons

Liquid Measure

1 centiliter = 10 milliliters = .34 fl. ounce
 1 deciliter = 10 centiliters = 3.38 fl. ounces
 1 liter = 10 deciliters = 33.81 fl. ounces
 1 dekaliter = 10 liters = 2.64 gallons
 1 hectoliter = 10 dekaliters = 26.42 gallons
 1 kiloliter = 10 hectoliters = 264.18 gallons

Square Measure

1 sq. centimeter = 100 sq. millimeters = .155 sq. inch
 1 sq. decimeter = 100 sq. centimeters = 15.5 sq. inches
 1 sq. meter (centare) = 100 sq. decimeters = 10.76 sq. feet
 1 sq. dekameter (are) = 100 sq. meters = 1,076.4 sq. feet
 1 sq. hectometer (hectare) = 100 sq. dekameters = 2.47 acres
 1 sq. kilometer = 100 sq. hectometers = .386 sq. mile

Cubic Measure

1 cu. centimeter = 1000 cu. millimeters = .06 cu. inch
 1 cu. decimeter = 1000 cu. centimeters = 61.02 cu. inches
 1 cu. meter = 1000 cu. decimeters = 35.31 cu. feet

Approximate Conversion Factors

To change	To	Multiply by	To change	To	Multiply by
inches	centimeters	2.540	ounce-inches	newton-meters	.007062
feet	meters	.305	centimeters	inches	.394
yards	meters	.914	meters	feet	3.280
miles	kilometers	1.609	meters	yards	1.094
square inches	square centimeters	6.451	kilometers	miles	.621
square feet	square meters	.093	square centimeters	square inches	.155
square yards	square meters	.836	square meters	square feet	10.764
square miles	square kilometers	2.590	square meters	square yards	1.196
acres	square hectometers	.405	square kilometers	square miles	.386
cubic feet	cubic meters	.028	square hectometers	acres	2.471
cubic yards	cubic meters	.765	cubic meters	cubic feet	35.315
fluid ounces	milliliters	29.573	cubic meters	cubic yards	1.308
pints	liters	.473	milliliters	fluid ounces	.034
quarts	liters	.946	liters	pints	2.113
gallons	liters	3.785	liters	quarts	1.057
ounces	grams	28.349	liters	gallons	.264
pounds	kilograms	.454	grams	ounces	.035
short tons	metric tons	.907	kilograms	pounds	2.205
pound-feet	newton-meters	1.356	metric tons	short tons	1.102
pound-inches	newton-meters	.11296			

Temperature (Exact)

°F Fahrenheit temperature 5/9 (after subtracting 32) Celsius temperature °C

PIN: 055208-000